



**LINEA MICRA.  
BRING THE  
CAFÉ HOME.**

LAMARZOCCO.COM

—  
linea micra  
**quick start  
guide**

—  
[WWW.LAMARZOCCO.COM](http://WWW.LAMARZOCCO.COM)

VIA LA TORRE 14/H  
50038 SCARPERIA E SAN PIERO  
FLORENCE - ITALY



**la marzocco**  
HOME



# linea micra overview

This Quick Start Guide is an overview of the basic steps for using your Linea Micra. For a more in-depth discussion of these topics, see the manual.

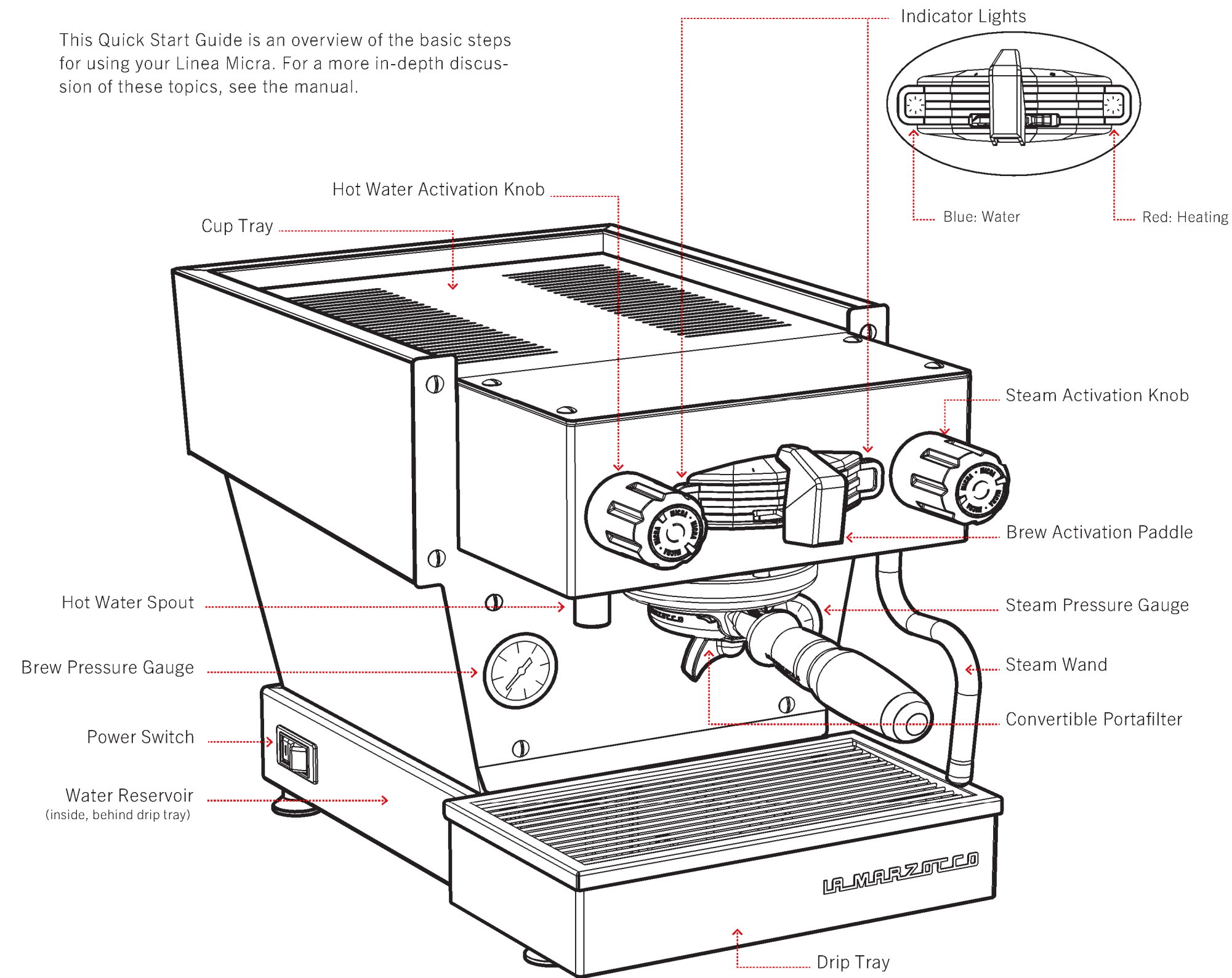

view complete instructions online at [www.lamarzocco.com](http://www.lamarzocco.com)

## unpacking & set up

You will need two people to lift the machine, it is over 19 kg (40 lbs.)

- With two people, lift the Linea Micra from the side and set on the counter (one hand under the front, one hand rear corner).
- Plug power cord into bottom of the machine and then plug machine into wall outlet.
- Remove the drip tray (lift up and pull out).
- Take cap off of reservoir.
- Pour water into reservoir. Replace reservoir cap.

Water quality is very important for the proper function of your machine. For information about water quality, please refer to the user manual.
- Replace drip tray.
- IMPORTANT: This step MUST be performed before the machine can be used.**

Turn on the machine. The water and heating indicator lights will flash, reminding us to prime the machine with water.

Move the handle to the brew position to start priming the machine with water. This must run for at least 25 seconds until the machine stops dispensing. At this point the handle can be moved to the off position and only the red light will flash, indicating that the machine is heating.
- Wait for the machine to warm up. The blinking red power light will turn solid when the coffee boiler reaches temperature and is ready to brew.

The gauge on the left will read between 1.3 and 2.0 when ready to steam.

special notes

Right red light blinks when the machine is heating, and will become solid red when it's ready to brew.

Left blue light will be solid when water is above the minimum fill level. When the reservoir is below the minimum fill level the blue light will start blinking.

## making coffee

You will need whole bean coffee, a grinder, a tamper, a knock box and a scale (optional, but recommended)

- Remove the portafilter from the Linea Micra and wipe out the filter basket so that it is clean and dry.
- If using a scale, set portafilter on the scale and tare it to zero.
- Dose the appropriate amount of coffee for the basket, if you are using the 17 gram basket, dose 17 grams or fill basket and swipe extra off the top.
- When you have dosed the desired amount, level out your coffee mound.
- Tamp the coffee in the basket, applying 9-14 kg (20 - 30 lbs.) of pressure with the tamper.
- Flush the group by moving the paddle to the BREW position and then STOP position.
- Insert portafilter into Linea Micra. Place your preferred cup(s) under the portafilter spouts. If using a scale, place the cup(s) directly on the scale and tare it to zero.
- Push the paddle to the left BREW position to start brewing. If your coffee is dialed in, you should achieve 28 - 34 grams (1 oz.) of espresso in 25 - 30 seconds.
- Push paddle back to the STOP position to stop the shot.
- Remove portafilter and discard the puck. For more information on making coffee visit [lamarzoccohome.com](http://lamarzoccohome.com) and navigate to the Education tab.

## steaming milk

You will need a steaming pitcher, cold milk, a towel, and a thermometer (optional)

- Fill the pitcher 1 cm below the spout indent on the interior of the pitcher with cold milk.
- Purge the steam wand by briefly turning the steam activation knob on and then back off.
- Insert wand into milk (at about 15 degrees) so the steam tip is just submerged and the surface of the milk lines up with the line on the steam tip.
- Turn on the steam and start aerating the milk, you'll want to listen for a few pops that let you know you are introducing air into the milk.

After the milk has expanded 30% - 50%, drop the tip into the milk to create a whirlpool motion. When the steam pitcher becomes hot (57° - 65° C / 135° - 150° F), turn off the steam.
- Purge the steam wand and clean with a damp cloth.
- Gently tap the pitcher and swirl to pop any bubbles and incorporate the foam floating on top with the liquid below.
- Pour into your cup with espresso.

## maintenance

You will need a short flathead screwdriver, medium sized bowl, hot water, Puro cleaning solution

- Fill medium sized bowl with hot water and add 6 grams (half tsp.) of Puro cleaning solution to water. Set aside.
- Remove portafilter and lift out the filter basket (may require use of screwdriver). Drop filter basket into medium sized bowl with cleaning solution.
- Place "blind" basket with no holes into portafilter. Add 3 grams of cleaning solution in to the blind basket.
- The cleaning cycle can be operated automatically using the La Marzocco home app, or manually by using the following method: Insert portafilter into machine and manually perform these steps:

  - 1x 15 seconds on, 30 seconds off.
  - 5x 5 seconds on, 5 seconds off.
  - Empty portafilter and turn on brewing cycle to flush out cleaning solution.
  - Re-insert portafilter and run 10 times for 5 seconds each.
- Place all parts (filter baskets and portafilter head) into medium sized bowl of hot water with cleaning solution.
- After the parts have soaked for 20 - 30 minutes, they will need to be wiped out and cleaned under running water.
- When done rinsing, dry and replace all the parts.
- Run an espresso through the machine to clean out any remaining cleaning solution.